

User manual and  
Spare Parts List

**GARUDAN**®

**GF-234-443&446 MH**



ANITA B, s.r.o.

Hliníky 2068

680 01 Boskovice

Czech Republic

tel: +420 516454774, 516453496

fax: +420 516452751

e-mail: [info@anita.cz](mailto:info@anita.cz)

[www.garudan.cz](http://www.garudan.cz)

--- CONTENTS ---

**Instruction Manual**

|  |   |
|--|---|
| <b>1. PREPARATION FOR OPERATION</b> .....                                    | 1 |
| 1) Lamp leads .....  | 1 |
| 2) Connection of control box .....   | 1 |
| 3) Adjustment of needle bar stop position .....                              | 2 |
| <b>2. CAUTIONS ON USE</b> .....  | 2 |
| 1) Lubrication (1) .....   | 2 |
| 2) Lubrication (2) .....   | 2 |
| 3) Adjustment of oiling to rotating hook .....                               | 2 |
| 4) Condition of oil lubrication .....  | 3 |
| 5) Cautions on operation .....   | 3 |
| <b>3. OPERATION</b> .....  | 3 |
| 1) How to attach needle .....  | 3 |
| 2) How to wind the lower thread .....  | 3 |
| 3) Selection of Thread .....   | 3 |
| 4) How to route the upper thread .....                                       | 4 |
| 5) Adjustment of stitch length and reverse sewing .....                      | 4 |
| 6) Setting bobbin .....  | 4 |
| 7) Threading of bobbin thread .....  | 5 |
| 8) Tension adjustment of bobbin threads .....                                | 5 |
| 9) Balance of thread tension .....   | 5 |
| 10) Needle thread tension .....  | 5 |
| 11) Adjustment of pressure of presser foot .....                             | 5 |
| 12) Timing between rotating hook motion and needle motion .....              | 6 |
| 13) Adjustment of Feed dog height .....                                      | 6 |
| 14) Adjustment the needle stop position .....                                | 6 |
| 15) Needle bar stop position (left & right).....                             | 7 |
| 16) Walking foot and presser foot vertical stroke adjustment .....           | 7 |
| 17) Relationship between rotating hook motion and take-up lever motion ..... | 7 |
| 18) Relationship between hook motion and opener motion.....                  | 7 |
| 19) Relationship between needle motion and feed dog motion .....             | 8 |
| 20) Safe clutch device .....   | 8 |

|  |    |
|--|----|
| 21) Adjustment .....   | 9  |
| 22) Installation of movable knife .....                                      | 9  |
| 23) Adjustment of thread trimmer cam .....                                   | 10 |
| 24) Adjustment of threads tension release assembly .....                     | 11 |
| 25) Adjustment of scissoring pressure of movable knife and fixed knife ..... | 11 |
| 26) Sharpening of fixed knife .....  | 12 |
| 27) Adjustment for change of needle-to-needle distance .....                 | 12 |

## Parts Catalog

|  |    |
|--|----|
| A、 ARM BED MECHANISM .....                       | 13 |
| B、 THREAD TENSION REGULATOR MECHANISM .....      | 16 |
| C、 ARM SHAFT*LOWER SHAFT MECHANISM .....         | 20 |
| D、 PRESSER FOOT MECHANISM .....                  | 22 |
| E、 NEEDLE BAR & TAKE-UP LEVER MECHANISM .....    | 25 |
| F、 TOP FEED ROCK SHAFT MECHANISM .....           | 28 |
| G、 LOWER SHAFT & FEED ROCK SHAFT MECHANISM ..... | 30 |
| H、 HOOK SADDLE MECHANISM .....                   | 33 |
| I、 KNIFT MECHANISM (1).....                      | 35 |
| J、 KNIFT MECHANISM (2) .....                     | 37 |
| K、 TOUCH BACK AND DETECTOR MECHANISM .....       | 40 |
| L、 OIL LUBRICATION MECHANISM .....               | 42 |
| J、 ACCESSORIES .....                             | 45 |

# 1. PREPARATION FOR OPERATION

## 1) Lamp Leads

- A. When installing the illuminating lamp (6V, 15-20W), The connecting wire is attached on the back of the Control box. It should be removed and connected by removing the insulating tube from the wire and stripping properly. The wire connections should be, then, insulated by wrapping insulating tape on the wires.

**CAUTION: The power switch must be turned off before connecting the lamp.**

- B. When the illuminating lamp is not used, the end of the lamp leads must be insulated as (a) or (b) as shown in the figure on right side. If a short circuit occurs failing to insulate, the transformer in the control box will be possibly burned out.

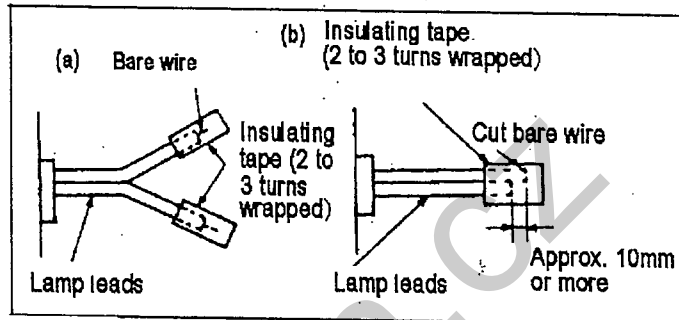

**CAUTION: The illuminating lamp must not be connected with any heater, such as a foot warmer and others, in parallel. Otherwise, the load capacity will be exceeded. It may cause transformer winding burned out.**

- C. Rotary direction

It is possible to change the rotary direction of the motor by removing the rubber cap from the bottom left side of the front cover on the control box, and push the internal direction selector switch. The built-in lamp in the internal switch is off when the motor is rotating counterclockwise as facing to the motor pulley, and on when rotating clockwise. The rotary direction has been set to counterclockwise as facing to the motor pulley, matching with the machine prior to shipping.

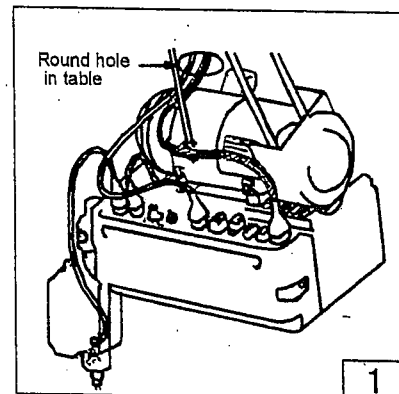

## 2) Connection of control box(Fig.1)

The control box should be connected as shown to the right.

Note:

- A. Be sure to turn the power switch off for safety before connecting or disconnecting the connectors.
- B. The combination of the machine heads with the motor control panels are specified below. Use special care for the correct combination when replacing the machine head or motor control panel.

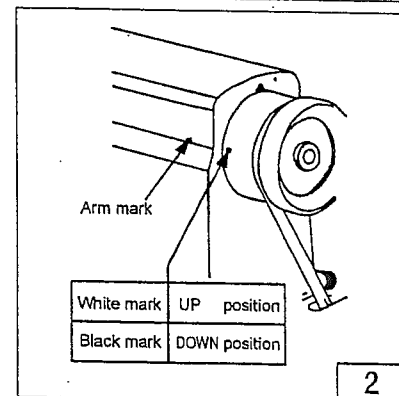

### 3) Adjustment of needle bar stop position(Fig.2, Fig.3)

A. Adjust of "UP" position: When the pedal is kicked down by heel, the machine stops at "UP" position.

If the marks deviate larger than 3 mm, adjust as follows.

- a. Disconnect the plug (12 pins) of cable from the machine head.
- b. Run the machine and stop at "UP" position.
- c. While holding the pulley, insert the "adjusting tool" in the hole "A", then remove the tool.

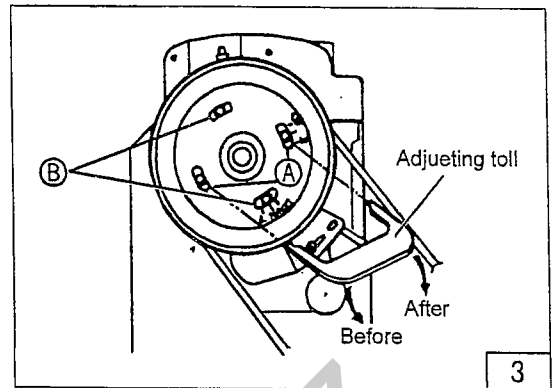

B. Adjust of "Down" position: When the pedal is "Neutral" the machine stops at "Down" position. If the marks deviate large than 5 mm, adjust as follows.

- a. Disconnect the plug (12 pins) of cable from the machine head.
- b. Run the machine and stop at "Down" position.
- c. While holding the pulley, insert the "adjusting tool" in the hole "B", then remove the tool.

C. Confirm the stop operation, then set the plug (12 pins) coming from the machine head into the receptacle.

## 2.CAUTIONS ON USE

### 1) Lubrication (1)(Fig.4)

Pour oil up to position "H" of the oil tank.

During operation, check the oil level periodically, and in cases where the oil level is below position "L", replenish the oil supply up to position "H".

Use white spindle oil.

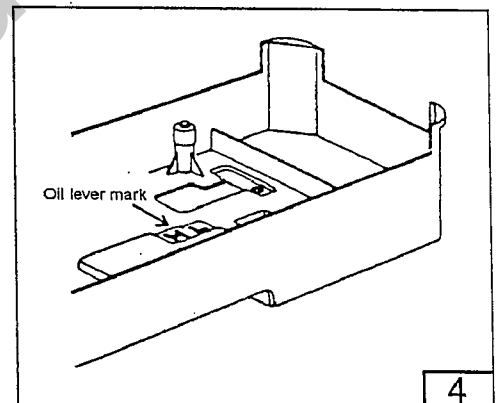

### 2) Lubrication (2)(Fig.5)

When a new sewing machine is used for the first time, or sewing machine left out of use for a long time is used again, replenish a suitable amount of oil to the portions indicated by arrow in the fig.

Note: Lubricate the Hook Base everyday.

### 3) Adjustment of oiling to rotating hook( Fig.6)

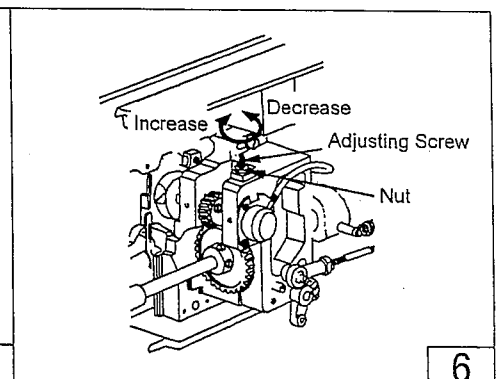
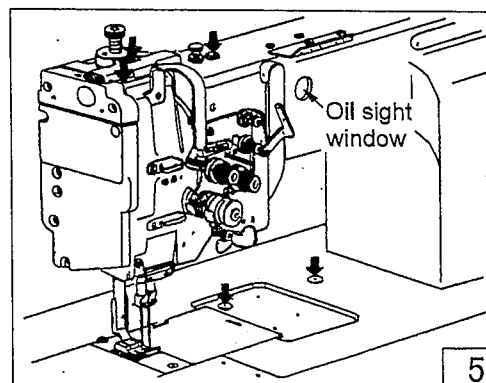

#### 4) Condition of oil lubrication (Fig.5):

While operating the machine, check the condition of oil lubrication through the oil check window.

#### 5) Cautions on operation

- A When the power is turned on or off, keep foot away from the pedal.
- B It should be noted that the brake may not work when the power is interrupted or power failure occurs during sewing machine operation.
- C Since dust in the control box might cause malfunction or control troubles, be sure to keep the control box cover close during operation.
- D Do not apply a multimeter to the control circuit for checking; otherwise voltage of multimeter might damage semiconductor components in the circuit.

### 3. OPERATION

#### 1) How to attach needle (Fig.7):

Note: Before attach needle, be sure to turn off the power.

Loosen the needle clamping screw; Hold the needles so that the two needles side with the long grooved (faces each other), and insert it as deeply as it will go into the needle clamping holes, tighten screws.

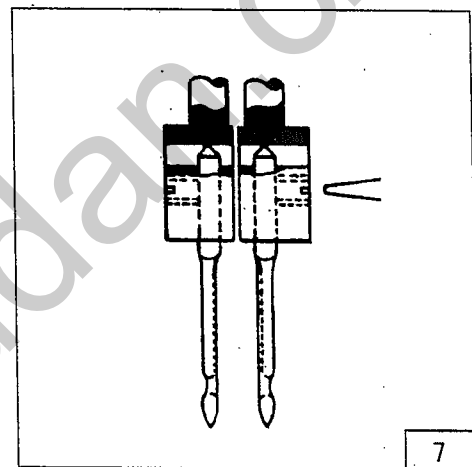

#### 2) How to wind the lower thread (Fig.8):

Strength of winding: Particularly in the case of nylon or polyester thread, wind the bobbin loosely.

Uneven winding: If the bobbin is wound unevenly, slide the thread guide toward the less wound portion of bobbin.

Winding amount: When the bobbin is wound excessively, loosen the adjusting screw. When the bobbin is wound insufficiently, tighten the adjusting screw.

#### 3) Selection of Thread (Fig.9):

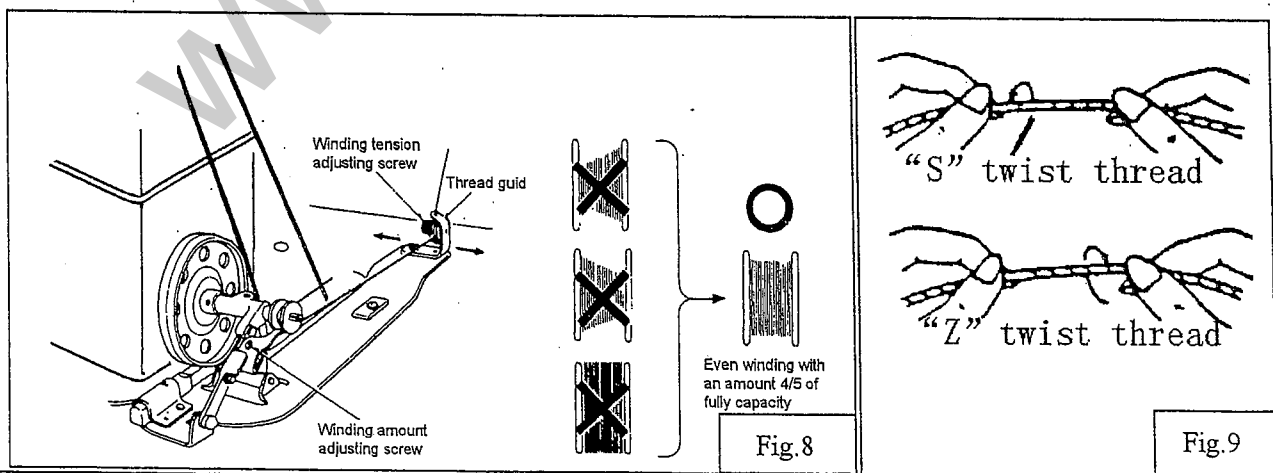

It is recommended to use "S" twist thread in the left needle (Viewed from front), and "Z" twist thread in the right needle.

When discriminate use of needle thread is impossible, use "Z" twist thread in the needle. For bobbin thread, "S" twist thread as well as "Z" twist thread can be used.

#### 4) How to route the upper thread (Fig.10, Fig.11):

A Pass each upper thread through thread guide A

**Note:** when thin slippery thread (polyester thread for example) is used pass the thread through thread guide B as show in Fig.10

B With the take-up lever located at the upper most position, pass each thread in the order in Fig. 11.

**Note:** Pressing the upper thread loosening button, the upper thread can be pulled out easily.

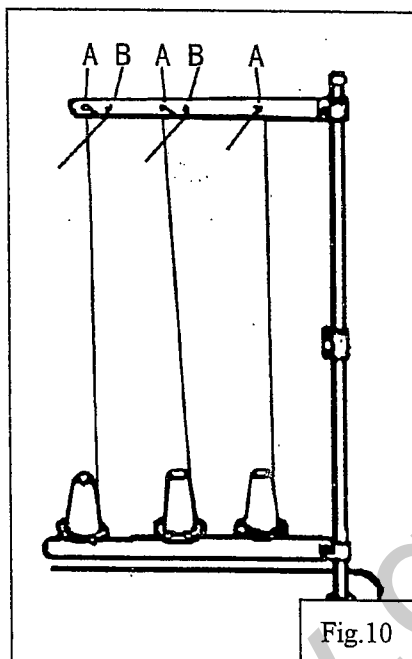

Fig.10

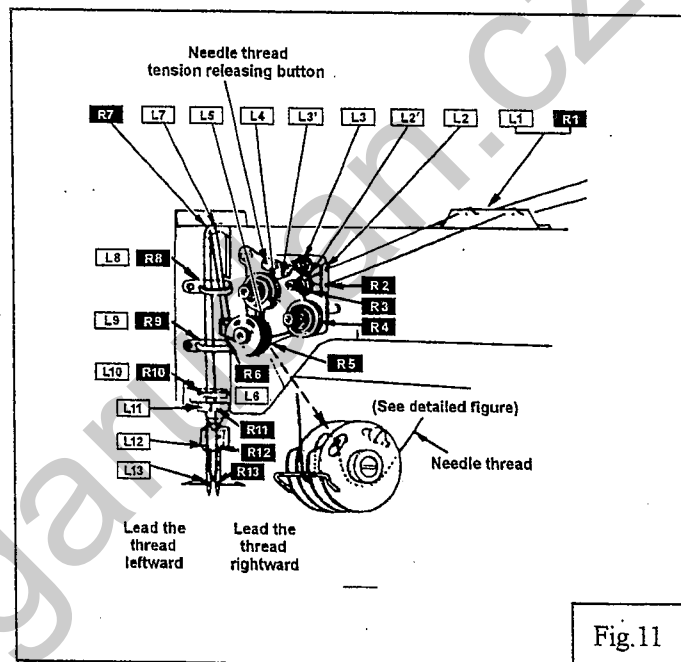

Fig.11

#### 5) Adjustment of stitch length and reverse sewing (Fig.12):

A Rotate the stitch length adjusting dial to change the stitch length

B Pressing the stitch length adjusting lever for reverse stitching.

#### 6) Setting bobbin (Fig.13):

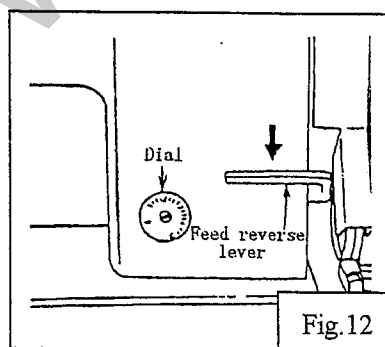

Fig.12

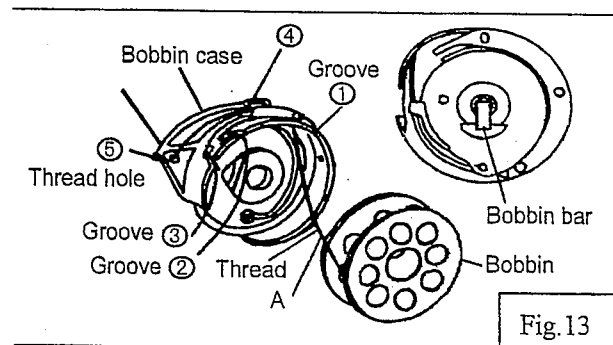

Fig.13



Leading the lower thread and install the bobbin

Pull out thread from side A , then install the bobbin case , Threading following ①~⑤; Put the bobbin case to rotating hook, then replace hook shaft; Press the bobbin bar, leading the lower thread over bedplate.

### 7) Threading of bobbin threads (Fig.14)

While holding the two needle Threads by left hand, rotate the hand-wheel one turn by right hand. By pulling up the needle threads, as shown in the figure, the bobbin threads will be lifted. Each combination of bobbin thread and needle thread should be aligned and led backward.

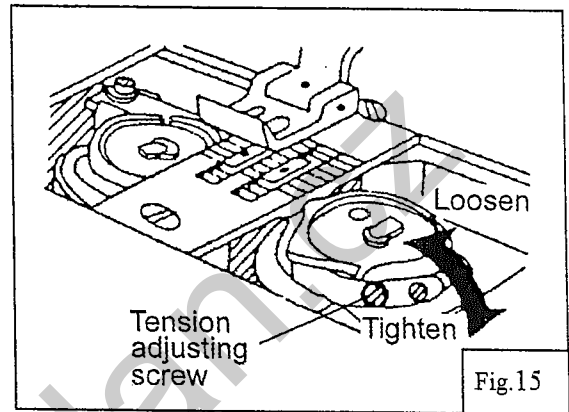
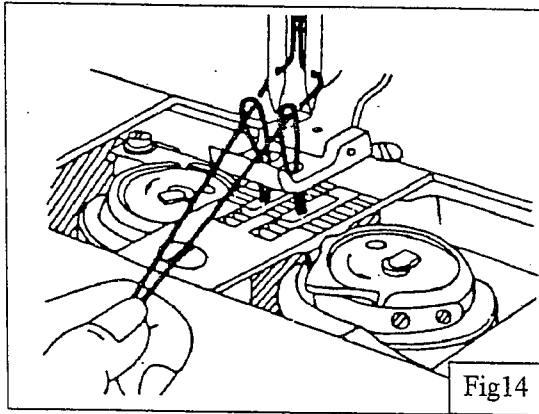

### 8) Tension adjustment of bobbin threads (Fig.15)

### 9) Balance of thread tension (Fig.16)

### 10) Needle thread tension (Fig.17)

Needle thread tension should be adjusted in reference to bobbin thread tension. To adjust needle thread tension, turn each tension adjusting nut. Needle thread tension can be also adjusted for special fabric and thread by changing intensity and movable range of slack thread adjusting spring.

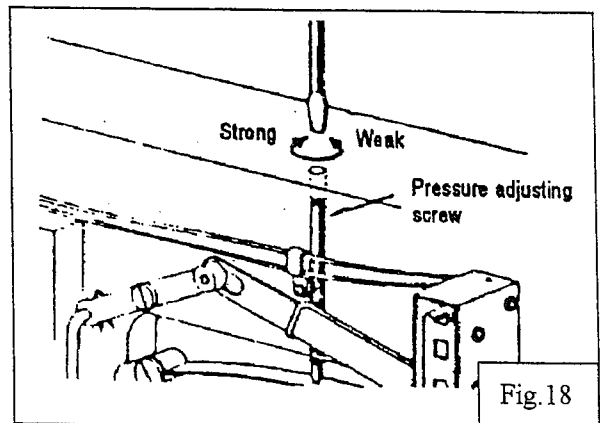
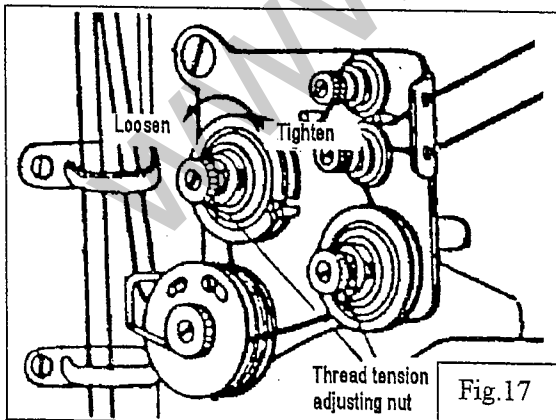
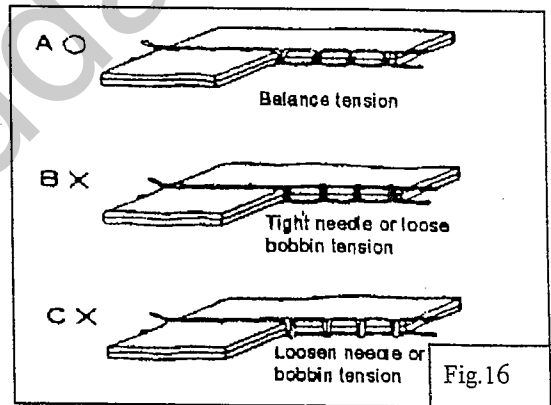

### 11) Adjustment of pressure of presser foot (Fig.18):

A Pressure should be adjusted according to the material to be sewn.

B. Turning the pressure adjusting screw to adjust the pressure of presser foot

**12) Timing between rotating hook motion and needle motion (Fig.19):**

- A. Set stitch length to "6";
- B. When needle is lifted 2.4mm from the lower dead point, the following position relationship should be maintained:
  - a. The upper edge of needle eye should be 2.3mm below the hook point
  - b. The hook point should be located at the center of needle axis.
  - c. Gap between the hook point and the side face of needle should be 0.05 mm

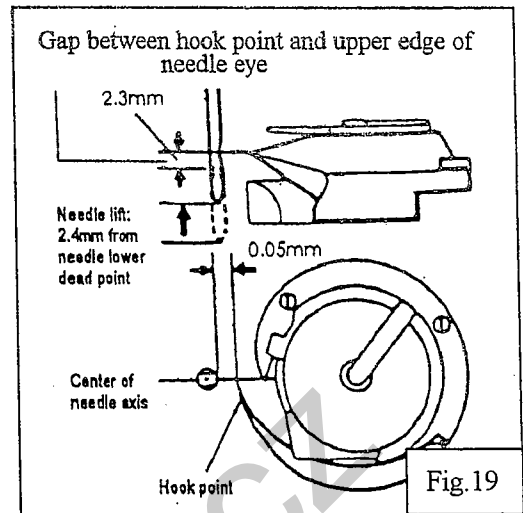

**13) Adjustment of Feed dog height (Fig.20):**

Height of feed dog should be adjusted for individual fabrics with the following cautions:

- A. Fabric will be damaged if the feed dog extends too high or pressure of presser foot is too large
- B. Even stitch length cannot be assured if the feed dog is too low or pressure of presser foot is too small
- C. Feed dog height should be measured at the point where the needle is at the top position.

For light fabric: Approx 0.8mm

For usual fabric: Approx 1.0mm

For heavy fabric: Approx 1.2mm

**Adjustment procedure:**

- A. Lay down the machine bed toward the other side;
- B. Turn the balance wheel by hand stop when the feed dog is raised to its highest position from the surface of needle plate;
- C. Loosen the Screw and adjust the height of the feed dog;
- D. After adjusted, tighten the screw.

The feed dog height is factory-adjusted to 1.2mm

**14) Adjustment the needle stop position (图 21):**

- A. Loosen the needle bar Screw A;
- B. Rotate the needle clamp B one circuit (amount of Adjustment is 0.6mm), or loosen the needle bar screw C, rotate position screw D half a circuit (amount of Adjustment is 0.3mm)
- C. Be sure to make the needle clamp facing left side, tighten needle bar screw C and A

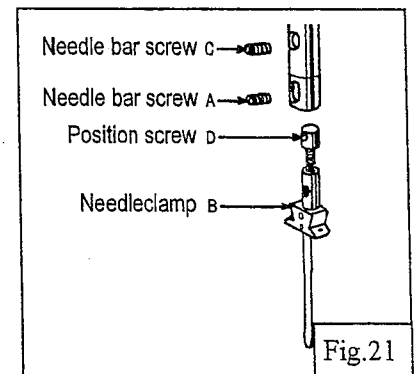
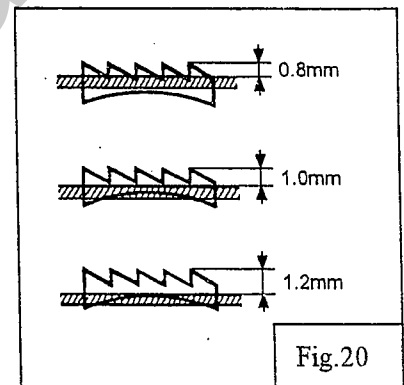

### 15) Needle bar stop position (left & right) (Fig.19):

- A Stop the motion of left-side needle bar:  
Make the stopper wrench to the position L.
- B Stop the motion of right-side needle bar:  
Make the stopper wrench to the position R.
- C Two needles running at the same time:  
Return the needle bar of left or right from standstill to running: Press down restore plate, stopper wrench restore to O position automatically

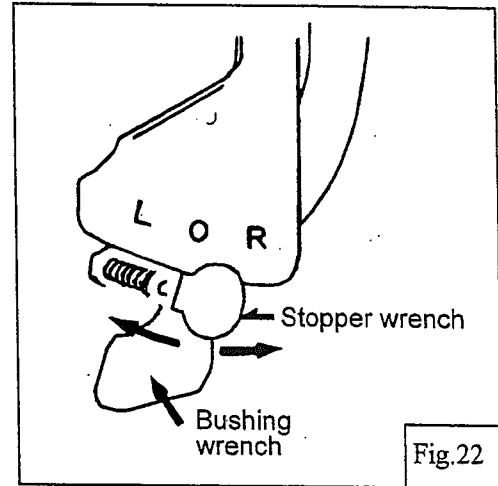

### 16) Walking foot and presser foot vertical stroke

#### adjustment (Fig.23):

When fabric with large elasticity is sewn, or when thickness of fabric changes, the vertical stroke (movable range) of the presser feet should be adjusted as follows:

- A Loosen the special bolt;
- B The vertical strokes of presser feet become minimum when the crank rod is moved downward and set;
- C The vertical strokes of presser feet become maximum when the crank rod is moved upward and set;
- D After the adjustment, tighten the special nut.

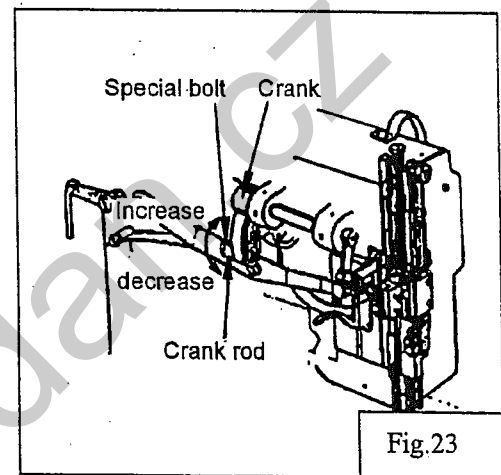

The vertical strokes of presser feet can be adjusted within a range from 2mm to 6mm.

### 17) Relationship between rotating hook motion and take-up lever motion (Fig.24)

When the timing belt (toothed belt) was removed for its replacement, for example, the relationship between rotating hook motion and take-up lever motion should be adjusted as follows:

- A Turn the balance wheel and stop when the take-up lever is lifted to its upper dead point.
- B Lean the machine head backward and make sure the arrow (timing mark) put on the timing belt is in line with the black line on the boss of lower shaft bearing.
- C If the timing mark is not in line with the black line, remove the timing belt and install it again to adjust.

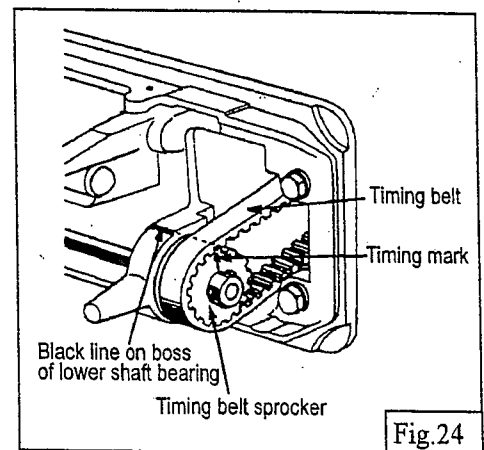

### 18) Relationship between hook motion and opener motion (Fig.25)

- A Turn the balance wheel by hand and stop when the opener holder is located most remotely from the

throat plate.

- B Make sure gap between the bobbin case holder A and the opener is approximately 0.2mm.
- C If the gap is too large or small, loosen the opener holder set screw B and adjust position of the opener.

### 19) Relationship between needle motion and feed dog motion

- A Set feed length to "0" on the feed setting dial
- B Lean the machine head backward. (Fig.26)
- C Loosen the feed lifting rockshaft crank set screws A and B
- D Set the needle at the lowest position. Adjust the distance between presser rod and vibration prevention rod to 9mm and temporarily tighten the feed lifting rockshaft crank set screws A and B. (Fig.27)
- E Check that the right feed lifting rockshaft crank is connected with the link at right angle, as shown in Figure.
- F If the connection is not at right angle, remove the back cover, loosen screw C and move the right link to connect the right feed lifting rock shaft with the link at right angle. (Fig.28)
- G After the completion of adjustment, fully tighten the screws A, B and C.
  - ♦ At this time make certain that needle can enter the feed dog needle hole at the center of the hole.

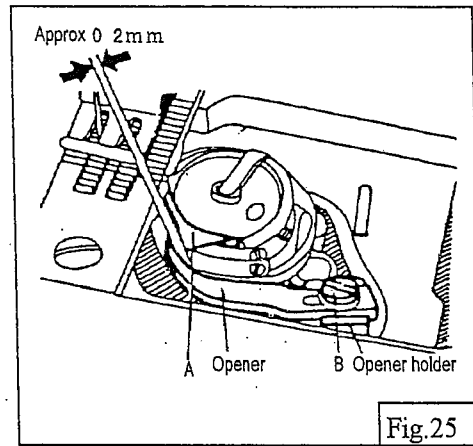

Fig.25

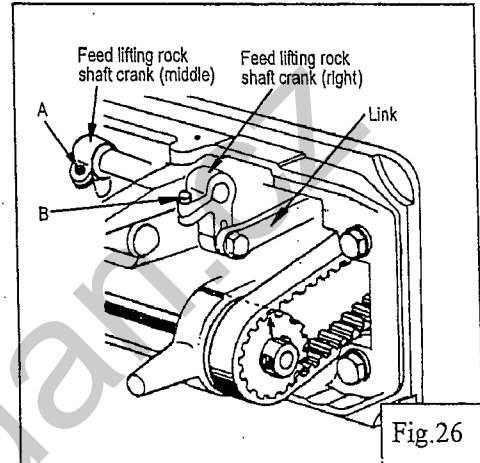

Fig.26

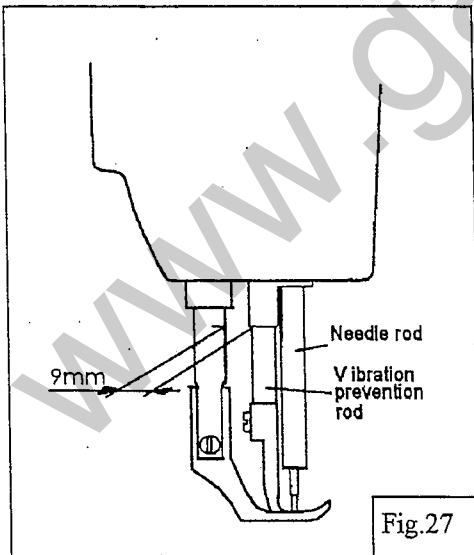

Fig.27

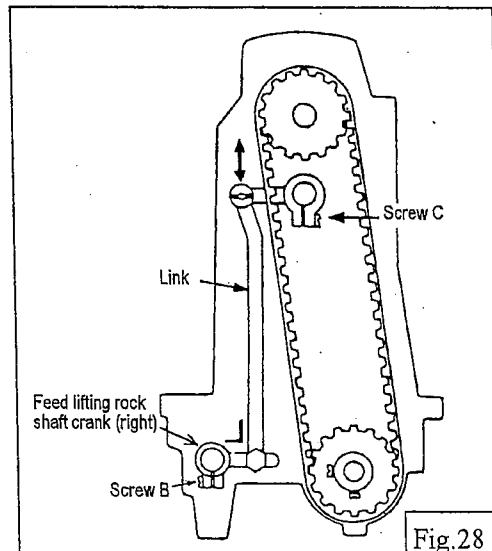

Fig.28

### 20) Safety clutch device (Fig.21, Fig.22) :

Safety clutch device is installed to prevent the hook and cog belt from damage in case the

thread is caught into the hook when the machine is loaded abnormally operation.

**A Function of safety clutch:**

- a. When the safety clutch acts, the cog belt pulley will be unloaded. Then the rotation of hook shaft will stop. The arm shaft only will rotate. Stop the operation of machine.
- b. Clean the thread thoroughly which is caught into the hook.
- c. Turn the cog belt hub by hand, and check whether the hook shaft rotates lightly and properly, place the clutch device as follows.

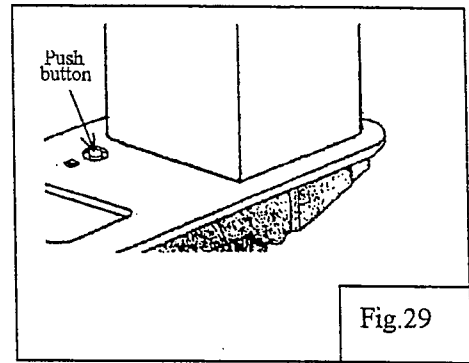

Fig.29

**B How to set the safety clutch (Fig.29)**

- a. While pressing down the push button on the opposite side of bed by left hand, turn the balance wheel slowly by right hand away from you;
- b. The balance wheel will stop by the gear plate, but turn the balance wheel more firmly;
- c. Release the push button, the safety clutch device is set.

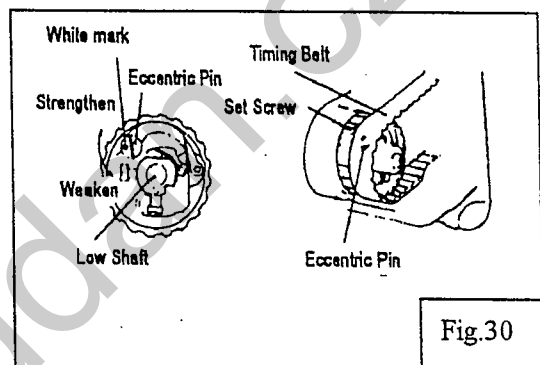

Fig.30

**C Force applied to the safety clutch (Fig.30)**

- a. The force applied to the safety clutch is the smallest when the mark of eccentric pin faces the center of the lower shaft. The force proportionally increases as the mark faces the outside;
- b. To adjust the force slide the timing belt, loosen the set screw, and turn the eccentric pin;
- c. After the adjustment, tighten the set screw.

**21) Adjustment**

Screwing the pin that connects the link of back-sewing with the crank of back-sewing (down) can adjust the tolerance of between the stitches.

Screwing the pin in clockwise can increase the stitch of forward sewing; otherwise, the stitch of back-sewing will be increased.

**22) Installation of movable knife**

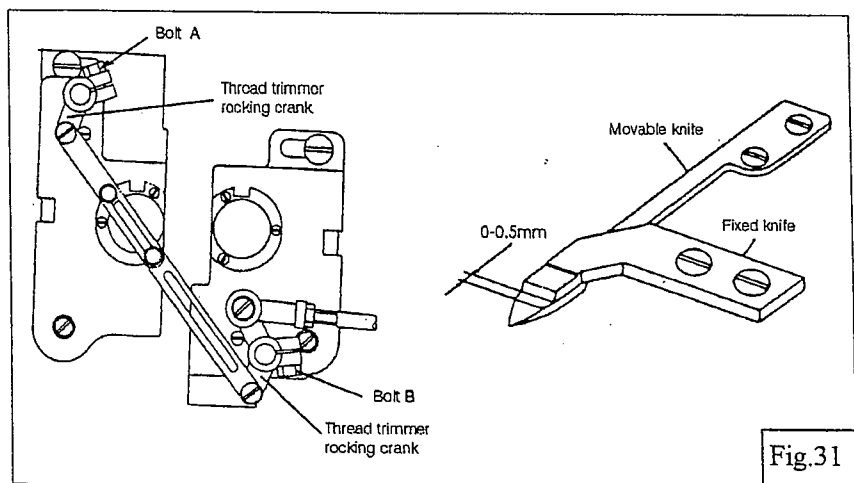
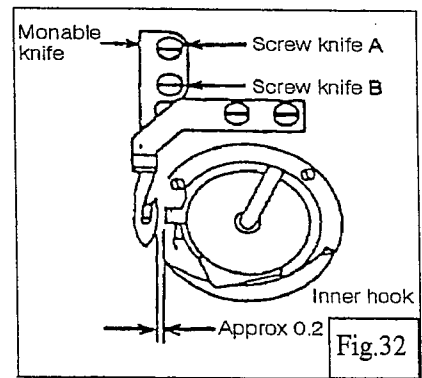

Fig.31

A Installation of movable knife (Fig.31)

- a. Turn the balance wheel and lower the needle bar to the lowest position.
- b. Push the cam follower crank so that the cam roller enters into the thread trimmer cam groove.
- c. Turn the balance wheel until the black mark point on the arm meets the white mark point on the balance wheel. Set the cam follower crank at this position with a screwdriver temporarily preventing the cam roller coming out from the cam groove.



- d. Loosen the thread trimmer rocking crank clamp bolts A and B.
- e. Adjust the movable knife so that the movable knife end slant portion protrudes 0-0.5 mm from the fixed knife, as shown in Figure and tighten the bolts A and B.

B Gap between movable knife and bobbin case holder stopper (Fig.32)

- a. Turn the balance wheel by hand until needle reaches the Lowest position.
- b. With the needle at the lowest position, depress cam follower crank, turn the balance wheel until the movable knife reaches the extremity of its stroke.
- c. Manually rotate the inner hook in the direction indicated by arrow in Figure and adjust gap between the movable knife and the inner hook stopper to about 0.5 mm (the screws A and B should be loosened for this adjustment).

**23) Adjustment of thread trimmer cam**

- A Turn the balance wheel by hand until the needles reach the lowest position.
- B Maintaining the needle position, depress the cam follower crank and put the cam roller into the groove of thread trimmer cam.
- C Turning the balance wheel by hand, adjust the thread trimmer cam so that the movable knife starts moving when the green mark point on the balance wheel comes in line with the black mark point on the arm.

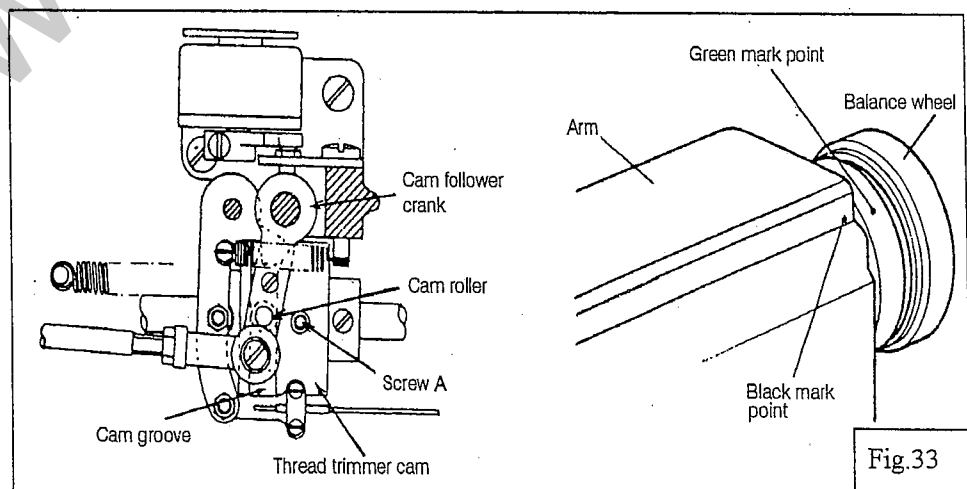

Note: To adjust, Loosen two thread trimmer cam clamp screws A.

#### 24) Adjustment of needle threads tension release assembly (Fig.34)

- A Turn the balance wheel by hand until the needles reach the lowest position.
- B Maintaining the needle position, depress the cam follower crank and put the cam roller into the groove of thread trimmer cam.
- C Turning the balance wheel by hand, adjust the thread tension release cam so that the tension disc close when the white mark point on the balance wheel comes in line with the black mark point on the arm.
- D To adjust, loosen two tension release cam clamp screws A.
- E Opening degree of tension disc should be adjusted with the tension release roller B mounted on the convex portion of thread release cam, as shown in Fig. To adjust, loosen the screws C and draw the wire.
- F Make fine adjustment by loosening the nut D.
- G Loosen the nut D and make the outer casing approach rightward to increase the opening value.

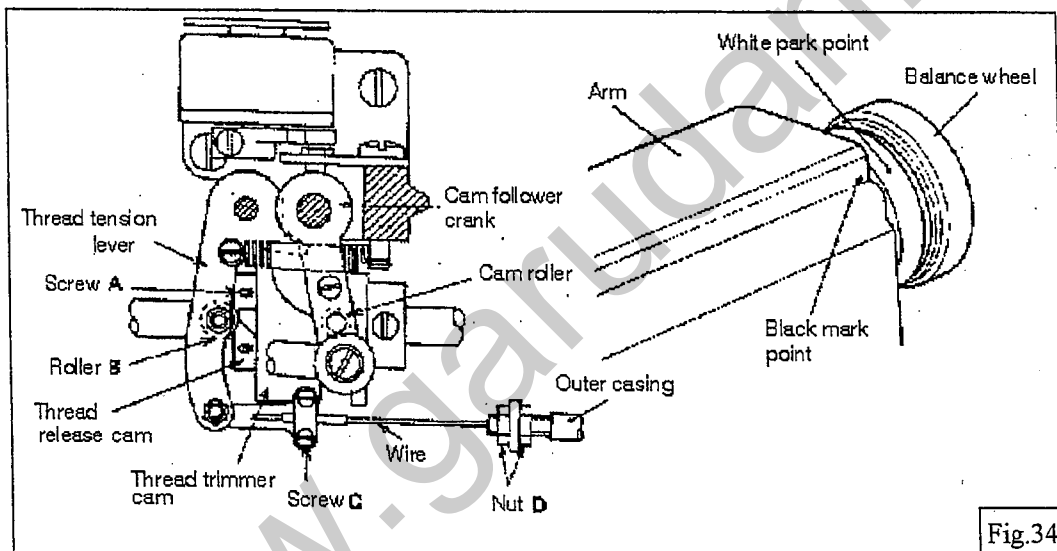

Fig.34

#### 25) Adjustment of scissoring pressure of movable knife and fixed knife (Fig.35)

- A Loosen the fixed knife bracket clamp bolt A.
- B Turn the vertical position adjusting screw B to adjust meshing pressure and then tighten the hexagon socket head cap screw A.

Note: Since excess pressure causes large torque to the thread trimming mechanism and trimming failure, adjust it so that thread can be trimmed with minimum pressure.

- C Move the movable knife and check that the thread can be sharply trimmed.

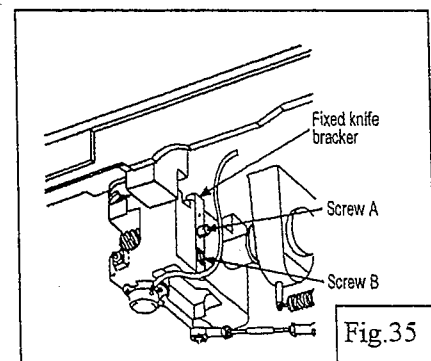

Fig.35

## 26) Sharpening of fixed knife

When the knives dull, the fixed should be sharpened as illustrated in Fig. Since it is very difficult to sharpen the movable knife, replace it with a new one when it dulls (Fig.36).

## 27) Adjustment for change of needle-to-needle distance (Fig.37)

- A Replace the throat plate, feed dog and needle clamp. (Since the throat plate and feed dog are special parts designed for thread trimming machine, be sure to use those specified by us.)
- B Lean the machine head backward.
- C Loosen two connecting link clamp bolts J.
- D Remove the spring M.
- E Loosen the hook bracket clamp screws A and B and adjust gap between each needle and hook.
- F When the needles and hooks have been adjusted, install the spring M.
- G Contact the rocking cranks C and D to the stopper pins E and F and tighten the connecting link clamp bolt J.
- H Turn the balance wheel by hand until the needles reach the lowest position.
- I Loosen the nuts G and H.
- J Depress the cam follower crank K and adjust the connecting rod L so that the cam roller can smoothly enter the groove of thread trimmer cam.

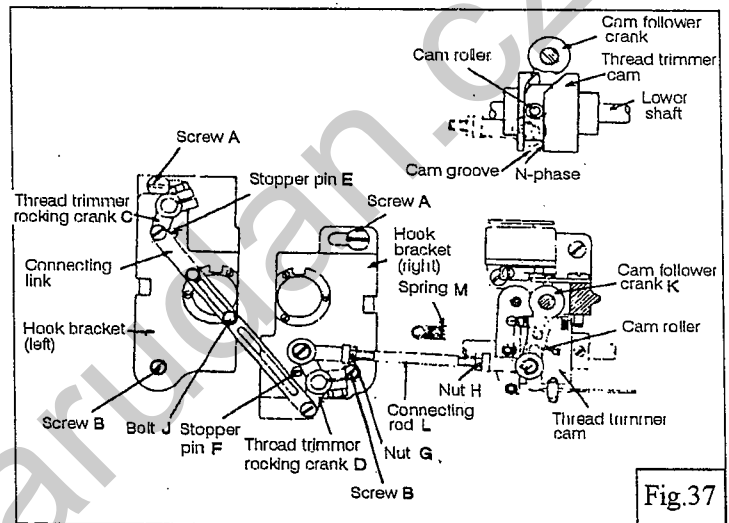
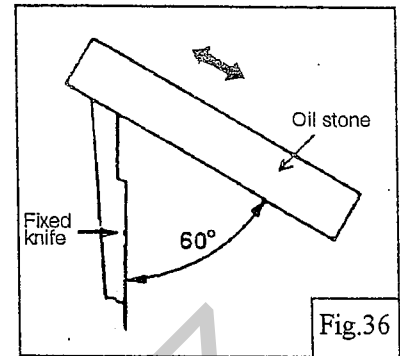

### Adjustment of the cam groove and the cam roller

- A Push the cam follower crank K so that the cam roller enters into the cam groove.
- B Turn the connecting rod L and adjust the clearance between the cam roller and the cam groove surface L as small as possible, and tighten the nuts G and H.
- C Push the cam follower crank K again and check that the cam roller enters into the thread trimmer cam groove smoothly.